

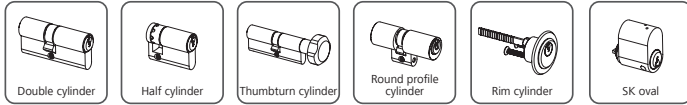

Installation and operating manual

For double cylinders, half cylinders, rim cylinders and thumbturn cylinders with a Euro profile, round profile and SK oval



1. General instructions







- According to manufacturer product liability as defined in the Product Liability Act, the following information on lock cylinders must be taken into account and passed on to users. Non-compliance releases EVVA from any liability.
- Lock cylinders are subject to dimension standard DIN 18252 (Except short cylinder with 6 pins (28/31, 28/36)) / Austrian standard ÖNORM B5356. Technical terms referring to lock cylinders and master key systems are described or illustrated in EN 1303, DIN 18252 (Except short cylinder with 6 pins (28/31, 28/36)) and ÖNORM B5356 if they are not explained in the EVVA Product catalogue.
- Lock cylinders can only be installed in locks, fittings and similar devices without any reservation if they comply with these dimensional standards and if such locks, fittings and similar devices are explicitly designed to accommodate the lock cylinders which comply with these standards.
- In all other cases, manufacturers, retailers and users of such locks, fittings and similar devices must be certain that the lock cylinder that they select is suitable for installation and its intended use. Applicable statutory regulations must be observed.
- Making any alterations to a lock cylinder may cause it to malfunction, so any changes should be avoided. Changes lead to loss of warranty and separately agreed guarantees.
- A lock cylinder with two locking sides (double cylinder) cannot be opened if a key is already inserted in the opposite side. If requirements stipulate that it must be possible to open a lock cylinder even if there is a key on the opposite side for safety reasons, lock cylinders with a so-called external key override function may be fitted.
- We recommend that you have lock cylinders installed by trained staff only. Lock cylinders and keys form a functional unit. EVVA shall assume liability for original EVVA products only.
- Architects and advisory institutions are obliged to request all necessary product information from EVVA and take all such information into account in order to comply with obligations regarding information and instructions under the Product Liability Act. Specialist retailers and installers are obliged to observe the EVVA installation and operating manual and, if applicable, to pass it on to their (end) customers.
- If panic locks are fitted, the installer must verify what type of lock cylinder is suitable.
- For cylinders with emergency function, the forceful blocking of the thumbturn may lead to a high friction force at the cam and the coupling and therefore higher resistance may need to be overcome while inserting the key.  These cylinders are specially marked at the key side.
- The instructions in the installation and operating manual must be observed!

2. Description

An EVVA lock cylinder for the purpose of this definition is a component that is commonly used in buildings and prepared for the installation of lock cylinders. Other types of lock cylinders are to be dealt with in a corresponding way. A lock cylinder is assigned at least one key. Lock cylinder and key form a single functional unit. EVVA shall only accept liability for our own original EVVA products.

Determining the correct cylinder length:

The diagram shown here illustrates the correct way to measure a lock cylinder.

-  Distance to door exterior
-  Distance to door interior
-  Fitting height on outside
-  Fitting height on inside
-  Cylinder length outside ($A = Ba + Ta$)*
-  Cylinder length inside ($I = Bi + Ti$)

* Lock cylinder lengths are available in 5 mm increments. If necessary, the outside cylinder length can be extended by 3 mm or reduced by 2 mm.

- Lock cylinder
- Locking cam
- Key
- Key bow
- Key bit
- Cylinder Fixing Screw ZS (M5 thread)

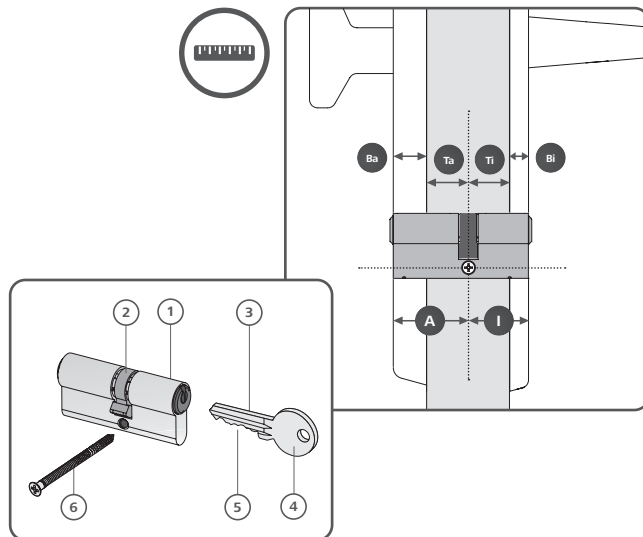

! Cylinder projection!

Lock cylinders in security-relevant installations or areas of use may not protrude more than 3 mm from the protective fitting. The extent of burglary-resistance measures is determined by the specified security objectives/requirements for the installation concerned (see EN 1627 and Austrian standards ÖNORM B5351 and ÖNORM 5338).

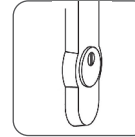

NOTE

If the cylinder does not comply with the required drilling and pulling protection in the break-in resistance class 1+2 pursuant to EN 1303, ÖNORM B 5338 and EN 1627-30, the cylinder may only be installed in connection with a suitable protective fitting with cylinder cover or security rose with cylinder cover.

! VdS-approved lock cylinders

The following information should be taken into account when installing VdS-approved lock cylinders!

- Lock cylinders without pulling protection – Class A
Lock cylinders in doors which are vulnerable to break-ins must be fitted with a VdS-approved, burglary-resistant door plate with Class-A pulling protection. Such door plates must comply with requirements under DIN 18257 Class ES 1 ZA.
- Lock cylinders with pulling protection – Class AZ
Lock cylinders in doors which are vulnerable to break-ins must be fitted with a VdS-approved, burglary-resistant door plate with Class-A pulling protection. Such door plates must comply with requirements under DIN 18257 Class ES 1.
- Lock cylinders without pulling protection – Class B (+)
Lock cylinders in doors which are vulnerable to break-ins must be fitted with a VdS-approved, burglary-resistant door plate with Class-B (+) or Class-C pulling protection. Such door plates must comply with requirements under DIN 18257 Class ES 2 ZA or ES 3 ZA.
- Lock cylinders with pulling protection – Class BZ (+)
Lock cylinders in doors which are vulnerable to break-ins must be fitted with a VdS-approved, burglary-resistant door plate with Class-B (+) or Class-C. Such door plates must comply with requirements under DIN 18257 Class ES 2 or ES 3.

3. Installation

- Insert the key in the lock cylinder as far as it will go.
- Turn the inserted key until the cam is flush with the cylinder housing. (The 30 degrees in the illustration are only an example)
A different key position may be required for different applications.
- Insert the lock cylinder into the cylinder opening in the lock case/door.
- Do not use any force when installing the lock cylinder.
- The lock cylinder is in the correct position in the lock case when the drill holes in the lock and lock cylinder are superimposed and the latch/bolt can be drawn back using the key.
- The front face of the profile cylinder body should be flush with the surface of the vulnerable side of the door or flush with its escutcheon cover. The front face of the profile cylinder may extend a max. of 3 mm proud of the outside door surface, and a max. of 2 mm proud of the door's inside surface. The extent of anti-burglary measures is determined by the specified protection objectives/requirements for the particular installation (see EN 1627, ÖNORM B5351 and DIN 18252).
- Straighten the key as soon as the lock cylinder is in the right position (Step 3) in the lock case.
- Secure the lock cylinder in the lock case with the cylinder screw. Fasten the screw by hand using a Phillips screwdriver (maximum tightening torque of 2.5 Nm). Also see section on Frequent Installation Errors

The locking function must be checked while holding the door in an **open** position. To do so, the lock bolt should be moved (open/locked position).

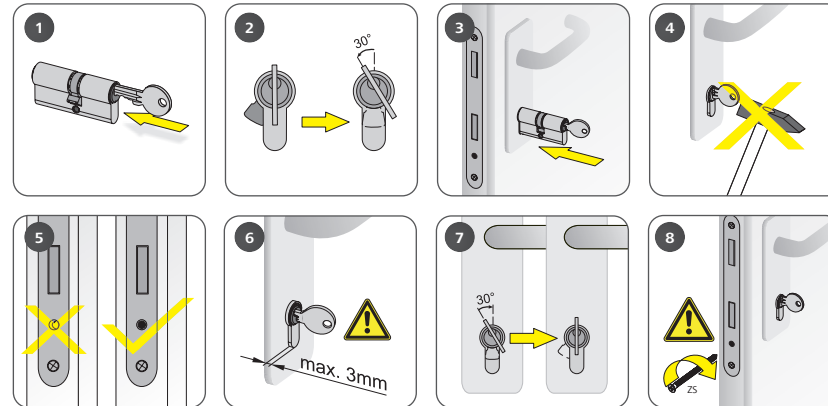

Attention!
If the cylinder screw is fastened too tightly, the cylinder may function incorrectly, may be stiff or may cause other problems.

NOTE:

Lock cylinders must be fitted in such a way that they are not subject to any external forces except when used correctly and at the designated mounting points. Similarly, when the key is removed, no external forces may be exerted on the cam or on the lever in the direction of turning.

4. Disassembly

The cylinder can be disassembled using the same procedure, but in reverse.

NOTE:

Ensure the lock cam is in the right position. Turn the key in such a way that the lock cam is aligned with the lower, elongated section. When replacing a cylinder, it is advisable to check the lock for any damage or dirt when you have disassembled the lock cylinder. You should dispose of lock cylinders, keys and packaging material in compliance with local regulations. Lock cylinder and key are classified as scrap metal for disposal purposes. We urgently recommend reporting the exchange of a lock cylinder or master key system to EVVA to ensure that the system documentation is adapted accordingly!

Required tools

We recommend using a PH2 Phillips screwdriver to fasten the lock cylinder into the lock case with cylinder screw.

Warning!

- ! You must not use other tools such as a hammer or pliers when fitting a lock cylinder. Ensure you apply the correct torque (2.5 Nm) if you use a battery-operated screwdriver.

5. Please note:

the product is incorrectly used, i.e. lock cylinders or keys are not used as intended, in the following cases:

1. Do not use tools such as screwdrivers, pliers or bunches of keys to increase the torque. Other lock picking tools must not be used. The key way and hence also the key shaft feature a slim design to ensure that torque can only be applied to the key bow by hand, thus guaranteeing that the cylinder can be reliably unlocked without any difficulty.
2. Lock cylinders may only be locked using original, authorised EVVA keys or keys manufactured by licensed EVVA partners. Do not lock or unlock lock cylinders using a tampered, bent or damaged key, or a copy supplied by an unauthorised manufacturer.
3. The key should not be used as a handle to open or close doors.
4. Do not apply force on the key bow from the side when the key is inserted in the cylinder (e.g. force applied using a key when it has not been completely withdrawn).
5. Only turn the key once it is fully inserted in the lock cylinder, i.e. when it has been inserted as far as it will go.
6. When inserting the key into the lock cylinder, ensure that you only exert pressure on the key from the front or the rear. If you apply pressure from the side, above or below, you are using the key incorrectly. If you are carrying the key on a lanyard, remove the key from the lanyard when locking or unlocking.
7. Depending on the degree or use of installation situation, we recommend lubricating the lock cylinder at least once a year.

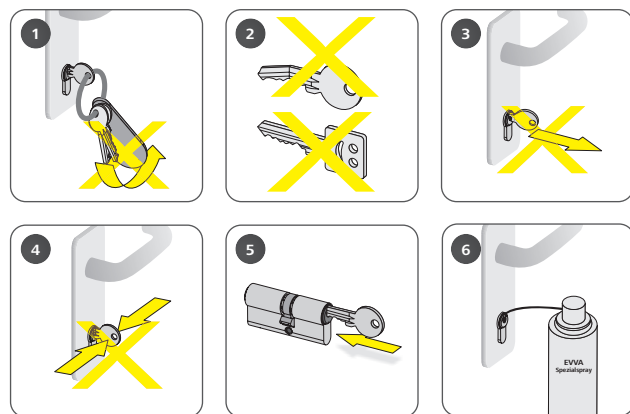

6. Correct usage

1. Only turn the key once it is fully inserted in the lock cylinder as far as it will go in the key way.
2. Lock cylinders for special applications, such as cold stores, must include special convenience, usage or security features.
3. The lock cylinder will only provide optimal security if used together with a security fitting.
4. You should check that keys work correctly in the corresponding lock cylinder while holding the door open.

7. Product performance features

Requirements for individual lock cylinders must be agreed with us in writing if the required product performance features have not been explicitly specified in our catalogues, leaflets, technical specifications or similar. Norm EN 1303 (Lock cylinders for door locks) serves as a guide in this respect. This standard specifies basic and supplementary requirements for lock cylinders. The content of the norm is to be applied to other lock cylinders accordingly. Lock cylinder serviceability depends on aspects such as frequency of use, the way it is used, environmental factors and maintenance. Lock cylinders and keys should be replaced as soon as any fault arises. This particularly applies to problems when inserting and removing keys.

8. Frequent installation errors

1. **Lock cylinder not fastened correctly.** The cylinder screw misses the hole in the lock cylinder and is driven under the cylinder. This is not easy to see, so check the lock cylinder to ensure it is securely fastened in position once you have installed it.
2. **Lock cylinder not fastened correctly.** The cylinder screw misses the hole and strikes against the lock cylinder.
3. **Screw too short.** A cylinder screw which is too short will miss the hole and the lock cylinder will not be fixed in position in the lock.
4. **Screw too long.** A cylinder screw which is too long will protrude from the face plate and the door cannot be closed or the screw enters too far into the lock case and prevents the cylinder from locking.
5. **Lock cylinder fastened correctly in position.** Insert the lock cylinder into the lock and fasten using a cylinder screw of the correct length (supplied by the lock manufacturer) at an angle of 90° (depending on the specific backset of the lock).

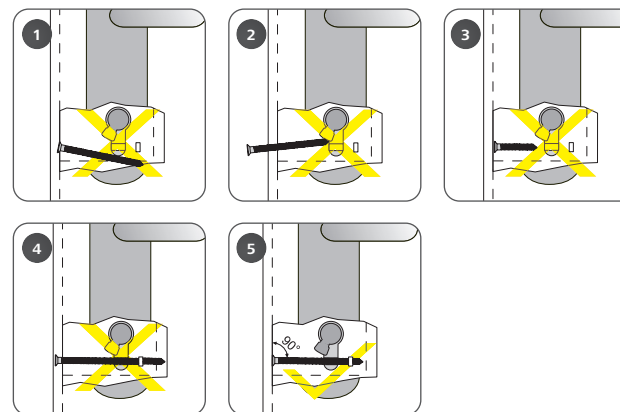

9. Maintenance

Lock cylinders should be lubricated on both sides at least once a year using the care product recommended by EVVA (EVVA special spray) (see Step 5/ Fig. 6).

- ! **Warning!** The use of corrosive cleaning agents or resinous oils may cause malfunctions or failure!

10. Information for optional functions

- ! **Cylinder with ZSD option**
Cylinders with the ZSD option have a drilling and plug pulling resistance, according to EN1303:2015 class D, on the marked "ZSD" cylinder side.

- ! **Lock cylinders with cogwheel cams (ZR)**
Always fit lock cylinders with cogwheel cams without the key

NOTE: The locking function must be checked while holding the door in an open position. You must verify that the lock cylinder/multi-point lock unit functions correctly as a whole.

- ! **Lock cylinder with free-wheel function for gear locks (FZG)**
Installation of free-wheel cylinder with self-disengaging free-wheel cams FZG and 360° free-wheeling cams are always fitted without a key.

NOTE:

This type of cylinder may only be fitted into multi-point gear locks with a panic function if the manufacturer explicitly requires forced lock cam disengagement to guarantee the panic function works correctly.

Read the lock manufacturer's instructions for use carefully before fitting the cylinder. The locking function must be checked while holding the door in an **open** position. The complete panic exit device including lock cylinder/panic lock/panic bar/handle set must be checked to ensure it works correctly.

In doing so, the following aspects must be taken into account for the panic function:

- ▶ The key may only be inserted when locking or unlocking the cylinder.
- ▶ The key must not be inserted during normal, day-to-day operations.
- ▶ The lock or multi-point lock must always be fully locked or unlocked as far as it will go to ensure that the bolt is fully retracted or extended.
- ▶ As a basic rule, requirements under EN 179 and EN 1125 apply

- ! **Cylinder lock with free-wheel function**
Cylinders with free-wheel function and a free-wheel cam are always installed without the key inserted. To ensure the free-wheel function, no key may be inserted.

- ! **External key override (BSZ): Limited function!**
When using a cylinder with an external key override (BSZ), you must ensure that nothing is blocking the opposite side of the cylinder (e.g. heavy bunch of keys).
NOTE: A lock cylinder with an external key override can be locked even if a valid key is inserted in the opposite side.